

RIGHT ANGLE PLUG CRIMP TYPE

R223.183.000

CABLE 2.6/50 D

Series : MMBX

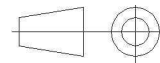
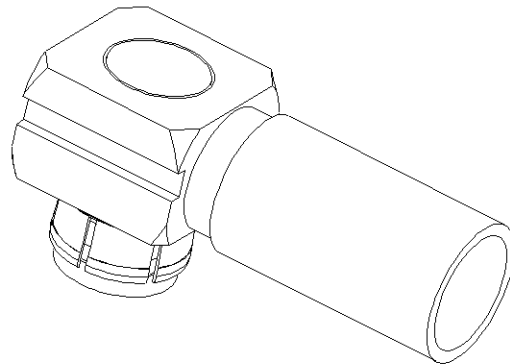
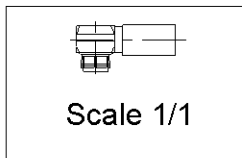
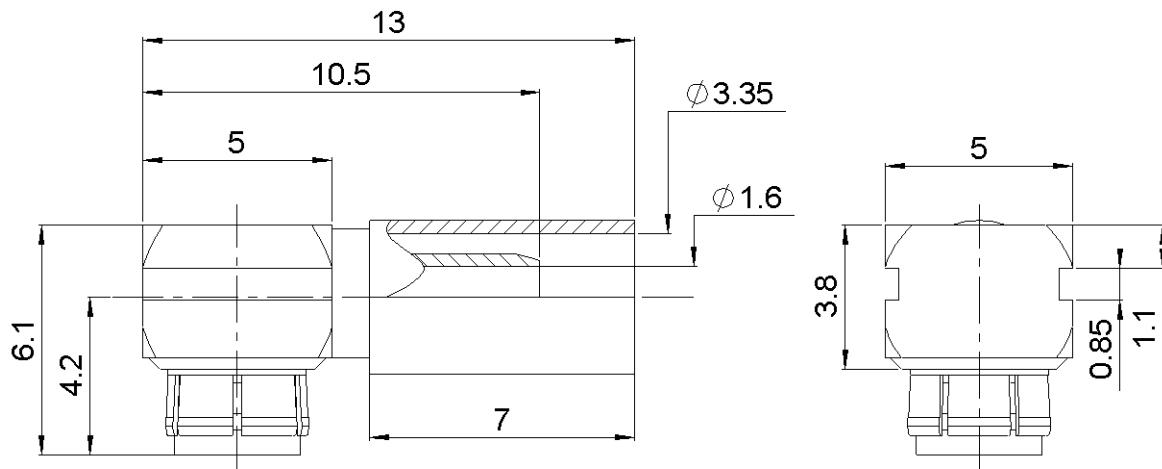

All dimensions are in mm.

COMPONENTS	MATERIALS	PLATING (µm)
BODY	BRASS	NPGR
CENTER CONTACT	BERYLLIUM COPPER	NPGR
OUTER CONTACT	BERYLLIUM COPPER	NPGR
INSULATOR	PTFE	
GASKET		
OTHERS PARTS	BRASS	NPGR
-	-	-
-	-	-

Issue : 0735 B

In the effort to improve our products, we reserve the right to make changes judged to be necessary.



RIGHT ANGLE PLUG CRIMP TYPE

R223.183.000

CABLE 2.6/50 D

Series : MMBX

PACKAGING

Standard	Unit	Other
100	'W' option	Contact us

SPECIFICATION

ELECTRICAL CHARACTERISTICS

Impedance		50 Ω
Frequency		0-12.4 GHz
VSWR	1.10* +	0,0350 x F(GHz) Maxi
Insertion loss		0.18 √F(GHz) dB Maxi
RF leakage	- (100** - F(GHz)) dB Maxi
Voltage rating		250 Veff Maxi
Dielectric withstanding voltage		750 Veff mini
Insulation resistance		1000 MΩ mini

CABLE ASSEMBLY

Stripping	a	b	c	d	e	f
mm	2,00	4,50	9,50	0,00	7,50	0,00

Assembly instruction :

Recommended cable(s)
K02252D

Characteristics indicated on this data sheet are those that can be achieved with the highest performance cable. Intrinsic limitations of the cable may diminish the performance of the assembly

Cable retention

- pull off	110 N mini
- torque	NA N.cm

MECHANICAL CHARACTERISTICS

Center contact retention		
Axial force – Mating end	10 N mini	
Axial force – Opposite end	10 N mini	
Torque	NA N.cm mini	

TOOLING

Part Number	Description	Hexagon
.	.	.
R282.235.906	CRIMPING DIES	3.3
R282.293.000	CRIMPING TOOL M22520/5-01	
R282.868.000	EXTRACTION ASSEMBLY TOOL	

Recommended torque		
Mating	NA N.cm	
Panel nut	NA N.cm	
Clamp nut	NA N.cm	
A/F clamp nut	0,0000 mm	

Mating life	100 Cycles mini
Weight	1,0000 g

OTHER CHARACTERISTICS

* to 6 GHz
** Interface MMBX only up to 2.5 GHz

ENVIRONMENTAL

Operating temperature	-55/+155 °C
Hermetic seal	NA Atm.cm3/s
Panel leakage	NA

Issue : 0735 B

In the effort to improve our products, we reserve the right to make changes judged to be necessary.



RIGHT ANGLE PLUG CRIMP TYPE

R223.183.000

CABLE 2.6/50 D

Series : MMBX

COMPONENTS

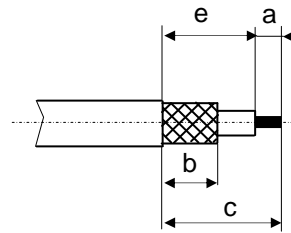
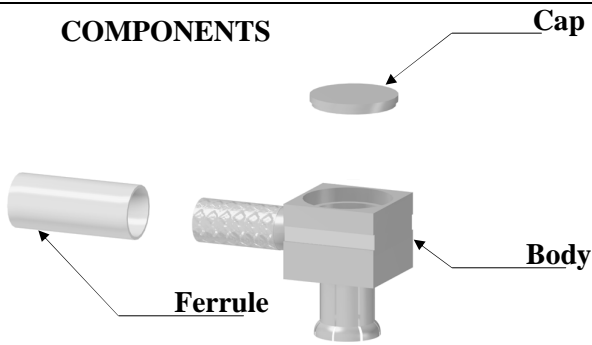

1

Slide the ferrule onto the cable.
Strip the cable.
Tin the cable inner conductor.

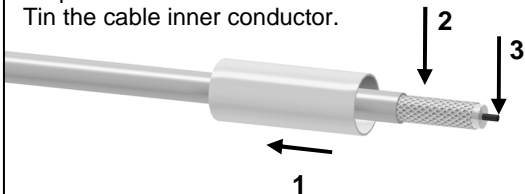

4

Crimp the ferrule with crimping tool (see connector TDS).
Solder the inner conductor.

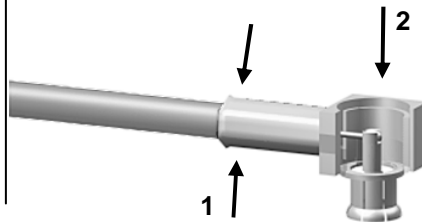

2

Fan the braid.



5

Place the insulator into the body.
Place the cap into the body.

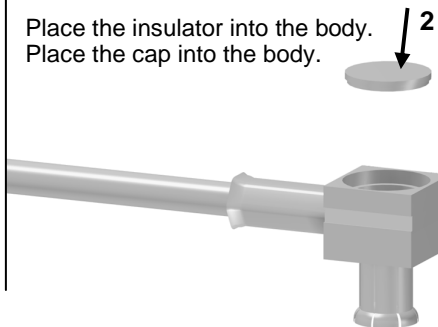

3

Push the connector body under the braid.
Slide the ferrule over the braid.

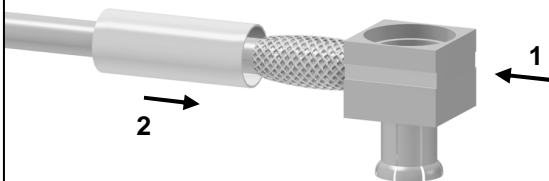

6

Slide mounting tool R282.868.000 onto the body grooves.
Drive the cap into rear opening of body by rotating the handle of the mounting tool.

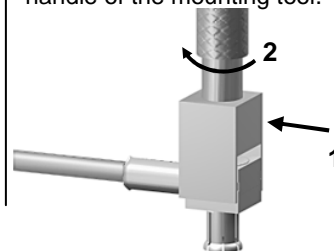

Issue : 0735 B

In the effort to improve our products, we reserve the right to make changes judged to be necessary.

